

\*NOW STOCKED IN CD4MCu

### AVAILABLE MOUNTING CONFIGURATIONS

8NNT-F FRAME MOUNT  
8NNT-RP-F REDI-PRIME FRAME MOUNT  
8NNT-EM ENGINE MOUNT  
8NNT-RP-EM REDI-PRIME ENGINE MOUNT  
8NNT-VC VERTICAL COUPLED  
8NNT-VF VERTICAL FRAME MOUNT

### OPERATING LEVELS

MIN FLOW	400 GPM	91 m <sup>3</sup> /h
MAX FLOW	4630 GPM	1052 m <sup>3</sup> /h
DISCHARGE SIZE	8"	203 mm
SUCTION SIZE	8"	203 mm
SOLIDS HANDLING	3.38"	86 mm
MAX SPEED	1900 RPM	1900 RPM
SHUT-OFF HEAD	122'	37.2 m
BEP HEAD	258'	79 m
BEP FLOW	3295 GPM	748 m <sup>3</sup> /h
BEP PERCENT	81%	81%



A typical picture of the pump is shown. Please contact StarTechPump Company for further details. All information is approximate and for general guidance only.

PARTS	STANDARD MATERIAL (ALL IRON)	CD4MCU
WEAR RING	CAST IRON	CD4MCU
IMPELLER	CAST IRON	CD4MCU
VOLUTE	CAST IRON	CD4MCU
SHAFT	STRESSPROOF STEEL	17-4PH
SHAFT SLEEVE	416 STAINLESS STEEL	316 STAINLESS STEEL
SUCTION COVER	CAST IRON	CD4MCU
MECHANICAL SEAL	TUNGSTEN CARBIDE VS. SILICON CARBIDE	TUNGSTEN CARBIDE VS. SILICON CARBIDE
BEARING FRAME	CAST IRON	CAST IRON

The 8NNT pump is designed with StarTech's renowned quality and durability. It features a 8" discharge, 8" suction, and enclosed impeller. Available in All Iron or CD4MCu materials. StarTech's patented Cycloseal® design is standard, with a Type 1 or 2 single mechanical seal with Buna-N elastomers, stainless steel hardware and tungsten carbide vs. silicon carbide seal faces for abrasion resistance.

**Frame mounted models:** Heavy-duty, grease lubricated, single row ball bearings with a minimum of 50,000 hours bearing life. **900/1200/1800 RPM operating speeds. Vertical configurations include an 8" suction elbow with other options available.** Uses an F18 frame (horizontal) or VC18 frame (vertical).

**Engine-mounted models:** 900/1800 RPM operating speeds.

- Cycloseal is Standard
- Heavy Duty Bearing Frame
- Two year Warranty

- **High Efficiency**
- Robust Construction
- Optional Redi-Prime Priming system



AGRICULTURE



FOOD



INDUSTRIAL



MINING



MUNICIPAL



OIL & GAS



REFRIGERATION



RENTAL

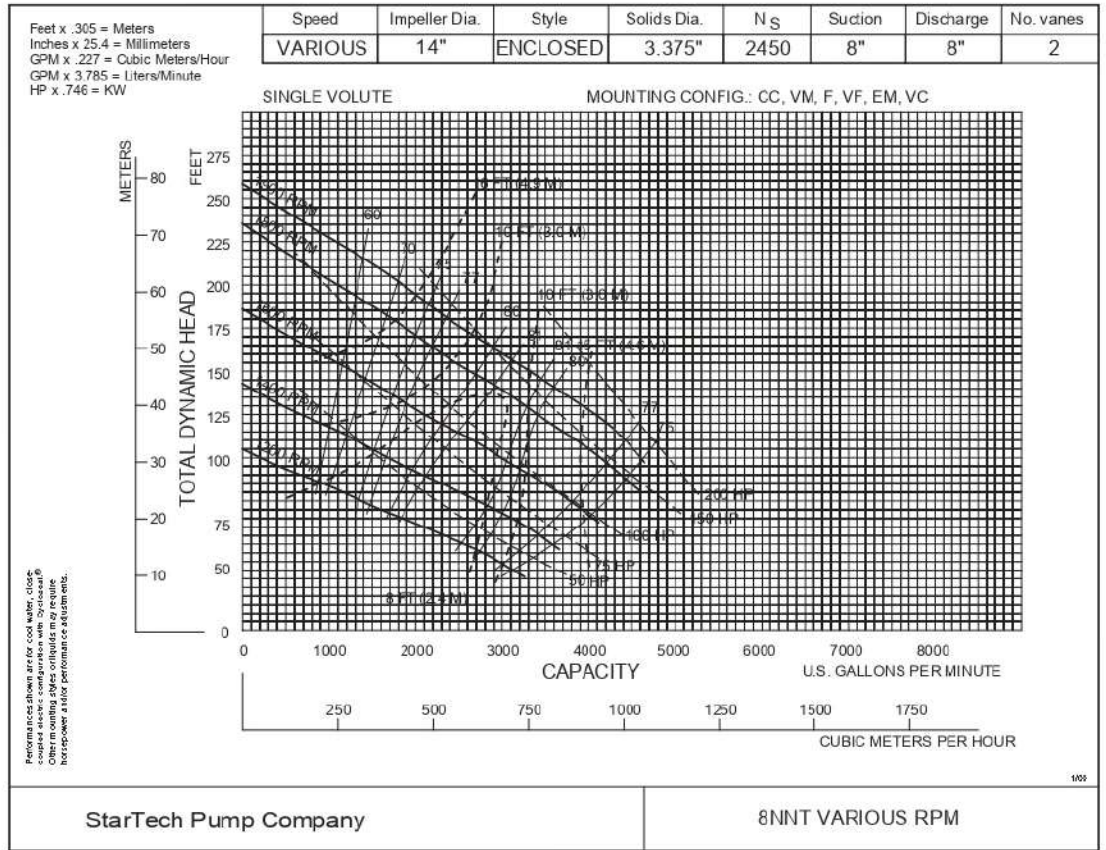

NEW PAGE

8NNTVA

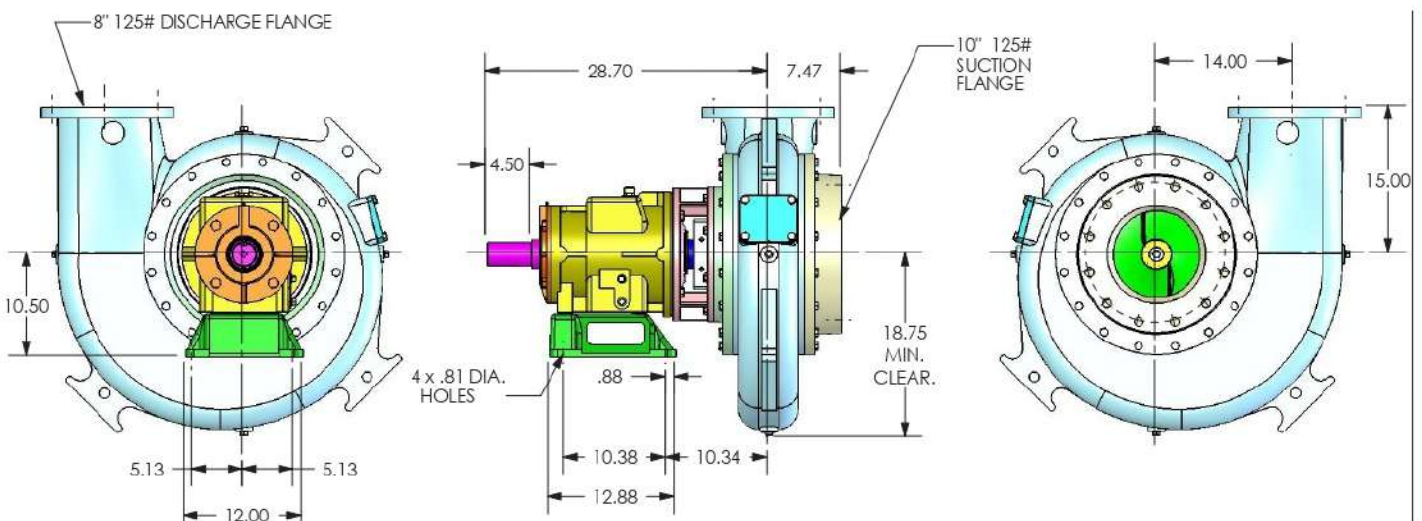

A typical pump configuration is shown. Drawings of other configurations available upon request.