

### AVAILABLE MOUNTING CONFIGURATIONS

8NHTH-F FRAME MOUNT  
8NHTH-RP-F REDI-PRIME FRAME MOUNT  
8NHTH-EM ENGINE MOUNT  
8NHTH-RP-EM REDI-PRIME ENGINE MOUNT  
8NHTH-VF VERTICAL FRAME MOUNT

### OPERATING LEVELS

MIN FLOW	800 GPM	182 m <sup>3</sup> /h
MAX FLOW	9390 GPM	2133 m <sup>3</sup> /h
DISCHARGE SIZE	8"	203 mm
SUCTION SIZE	10"	254 mm
SOLIDS HANDLING	4"	102 mm
MAX SPEED	1800 RPM	1800 RPM
SHUT-OFF HEAD	460'	140 m
BEP HEAD	300'	91.44 m
BEP FLOW	6200 GPM	1407 m <sup>3</sup> /h
BEP PERCENT	81%	81%



A typical picture of the pump is shown. Please contact StarTech Pump Company for further details. All information is approximate and for general guidance only.

PARTS	STANDARD MATERIAL (ALL IRON)
WEAR RING	CAST IRON
IMPELLER	DUCTILE IRON
VOLUTE	DUCTILE IRON
SHAFT	17-4PH
SHAFT SLEEVE	416 STAINLESS STEEL
BACKPLATE	DUCTILE IRON
MECHANICAL SEAL	TUNGSTEN CARBIDE VS. SILICON CARBIDE
BEARING FRAME	CAST IRON

The 8NHTH pump is designed with StarTech's renowned quality and durability. It features an 8" discharge, 10" suction, enclosed impeller, and tangential double volute. StarTech's patented Cycloseal® design is standard, with a Type 1 or 2 single mechanical seal with Buna-N elastomers, stainless steel hardware and tungsten carbide vs. silicon carbide seal faces for abrasion resistance.

- Cycloseal sealing system
- Robust construction
- **High efficiency hydraulics**
- Oversize shaft and bearings
- Optional Redi-Prime Priming system
- Two-year warranty



AGRICULTURE



FOOD



INDUSTRIAL



MINING



MUNICIPAL



OIL & GAS



REFRIGERATION



RENTAL

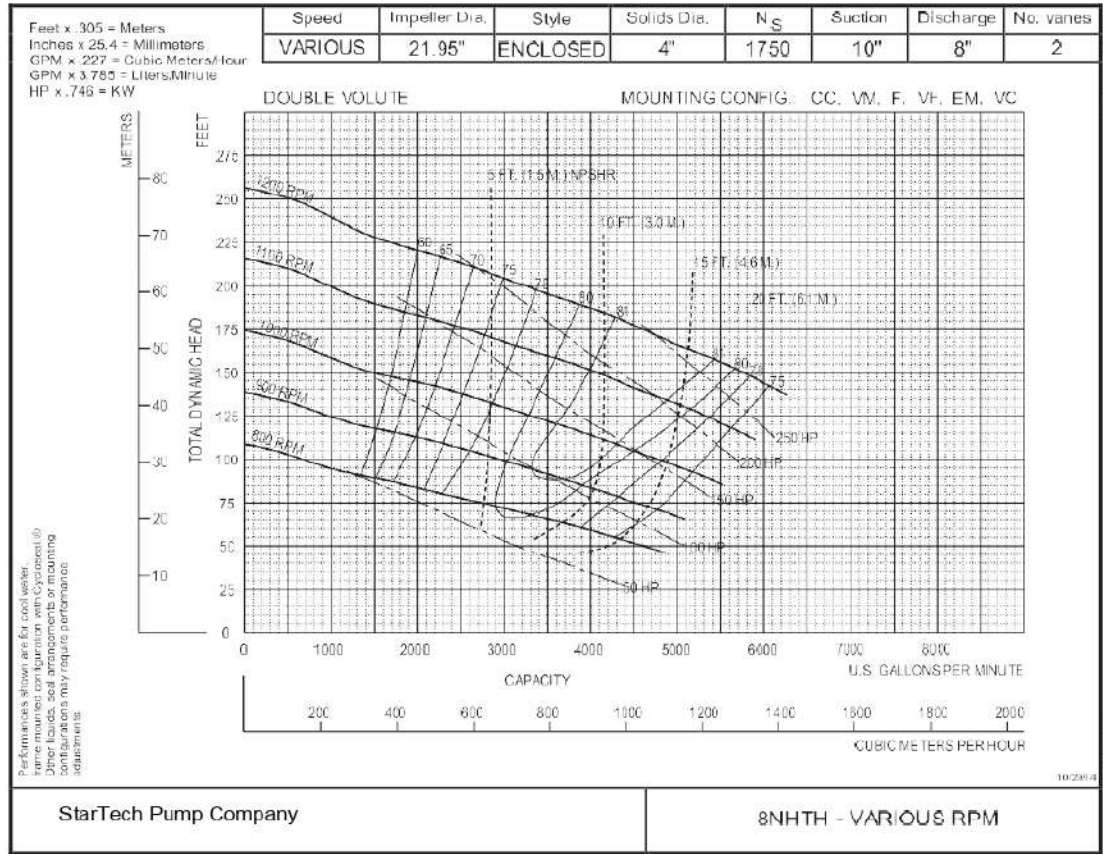

NEW PAGE

8NHTHVA

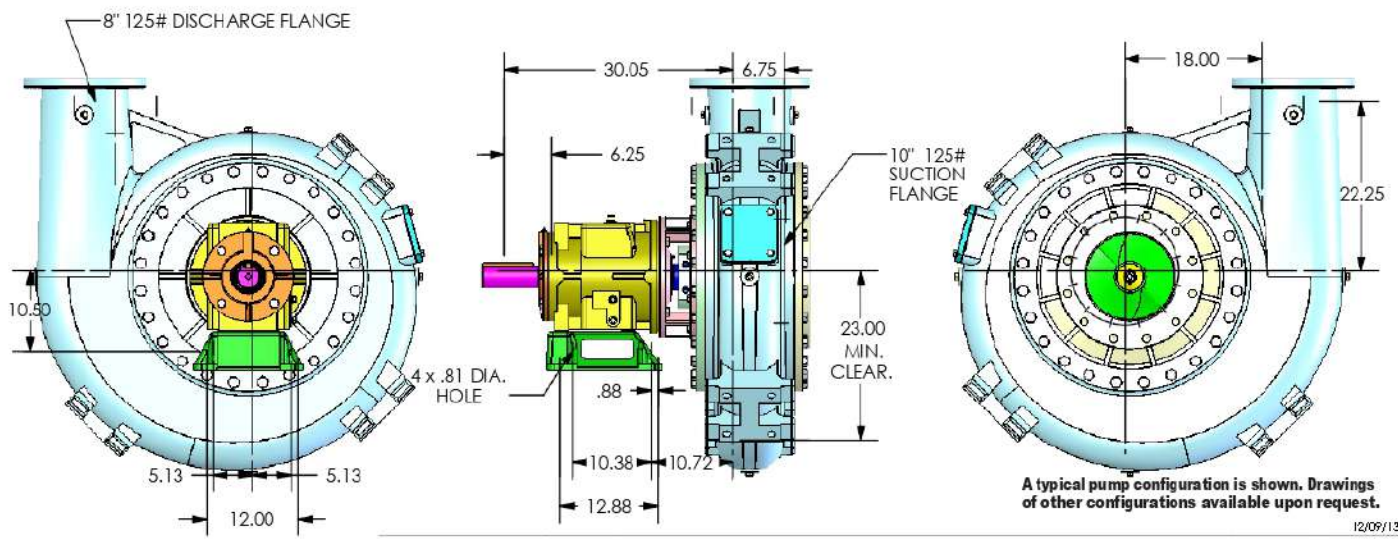

DS8NHTH-103114