

\*NOW STOCKED IN CD4MCu

### AVAILABLE MOUNTING CONFIGURATIONS

8NHTA-F FRAME MOUNT  
8NHTA-RP-F REDI-PRIME FRAME MOUNT  
8NHTA-EM ENGINE MOUNT  
8NHTA-RP-EM REDI-PRIME ENGINE MOUNT  
8NHTA-VF VERTICAL FRAME MOUNT

### OPERATING LEVELS

MIN FLOW	400 GPM	91 m <sup>3</sup> /h
MAX FLOW	5100 GPM	1158 m <sup>3</sup> /h
DISCHARGE SIZE	8"	203 mm
SUCTION SIZE	10"	254 mm
SOLIDS HANDLING	3.38"	86 mm
MAX SPEED	1800 RPM	1800 RPM
SHUT-OFF HEAD	350'	107 m
BEP HEAD	219'	67 m
BEP FLOW	3697 GPM	840 m <sup>3</sup> /h
BEP PERCENT	82%	82%



A typical picture of the pump is shown. Please contact StarTech Pump Company for further details. All information is approximate and for general guidance only.

PARTS	STANDARD MATERIAL (ALL IRON)	CD4MCU
WEAR RING	CAST IRON	CD4MCU
IMPELLER	CAST IRON	CD4MCU
VOLUTE	CAST IRON	CD4MCU
SHAFT	4140/4142 BD	17-4PH
SHAFT SLEEVE	416 STAINLESS STEEL	316V STAINLESS STEEL
MECHANICAL SEAL	TUNGSTEN CARBIDE VS. SILICON CARBIDE	TUNGSTEN CARBIDE VS. SILICON CARBIDE
BEARING FRAME	CAST IRON	CAST IRON

The 8NHTA pump is designed with StarTech's renowned quality and durability. It features an 8" discharge, 10" suction, and enclosed impeller. Available in All Iron or CD4MCu materials. StarTech's patented Cycloseal® design is standard, with a Type 1 or 2 single mechanical seal with Buna-N elastomers, stainless steel hardware and tungsten carbide vs. silicon carbide seal faces for abrasion resistance.

- Cycloseal sealing system
- Robust construction
- **High efficiency hydraulics**
- Oversize shaft and bearings
- Optional Redi-Prime Priming system
- Two-year warranty



AGRICULTURE



FOOD



INDUSTRIAL



MINING



MUNICIPAL



OIL & GAS



REFRIGERATION



RENTAL

# 8NHTA-F

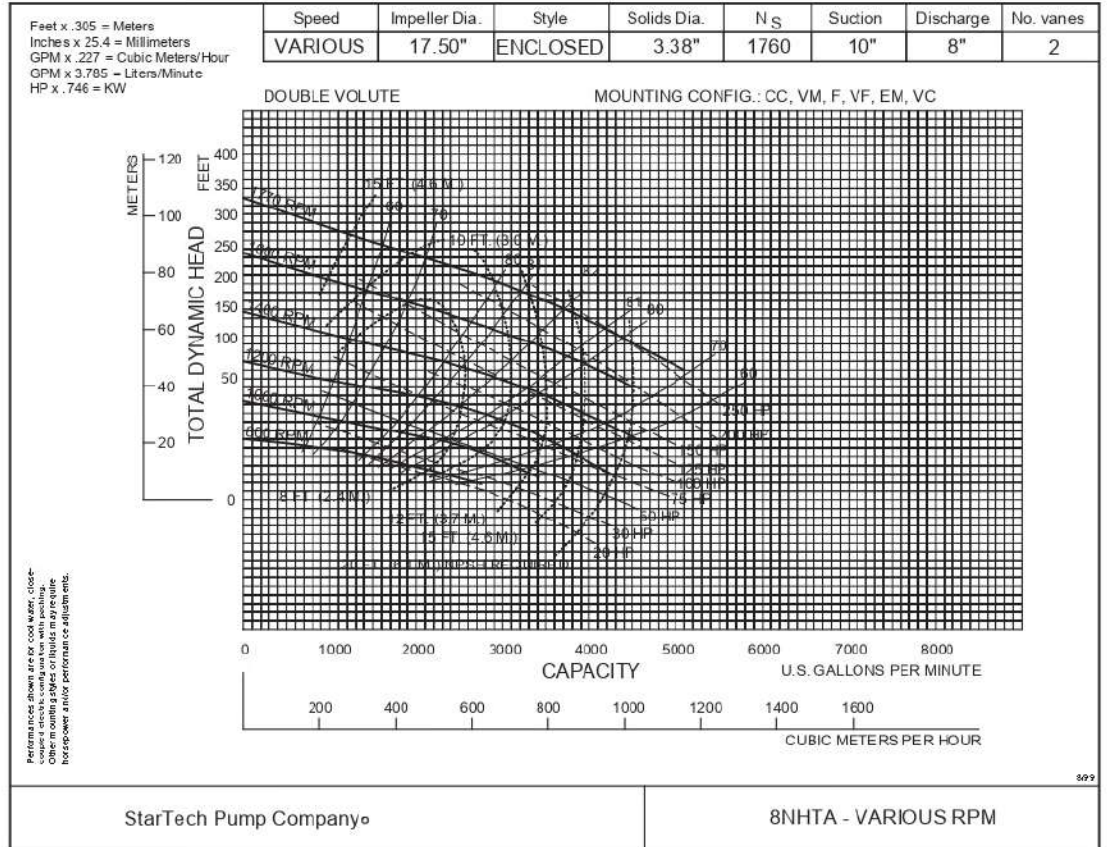

NEW PAGE

8NHTA

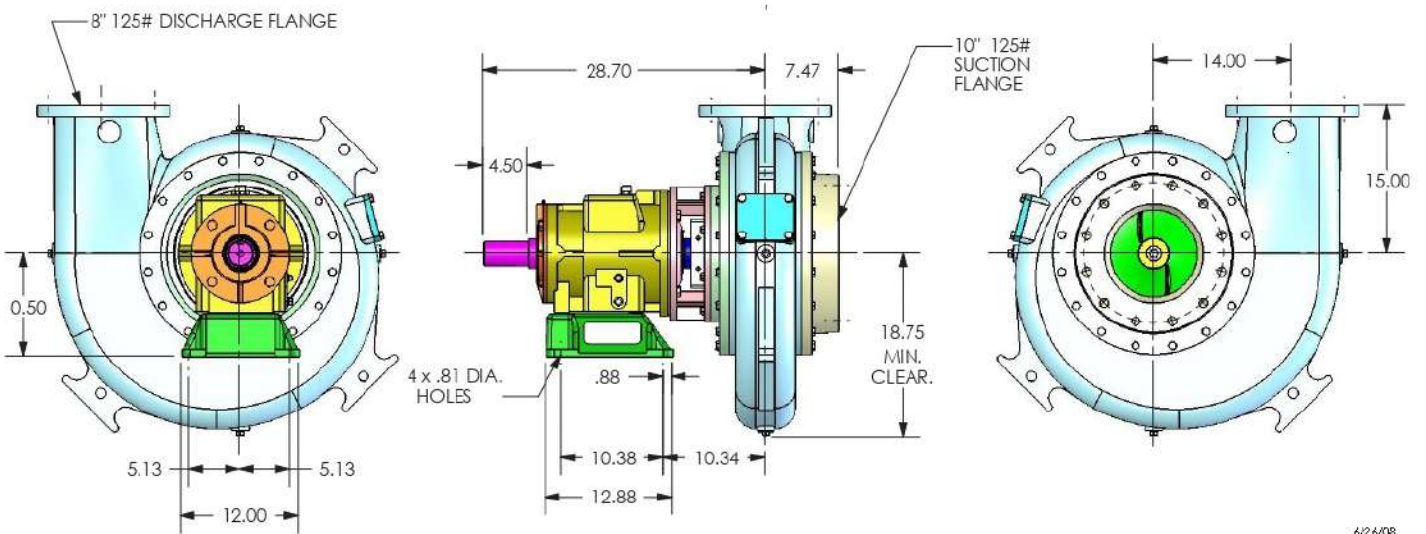

6/26/08