

### AVAILABLE MOUNTING CONFIGURATIONS

5RB-F FRAME MOUNT  
5RB-RP-F REDI-PRIME FRAME MOUNT  
5RB-EM ENGINE MOUNT  
5RB-RP-EM REDI-PRIME ENGINE MOUNT  
5RB-VF VERTICAL FRAME MOUNT  
5RB-VC VERTICAL COUPLED

### OPERATING LEVELS

MIN FLOW	265 GPM	60.1 m <sup>3</sup> /h
MAX FLOW	3000 GPM	681 m <sup>3</sup> /h
DISCHARGE SIZE	5"	127 mm
SUCTION SIZE	8"	203 mm
SOLIDS HANDLING	1"	25.4 mm
MAX SPEED	2400 RPM	2400 RPM
SHUT-OFF HEAD	370'	113 m
MAX WORKING PRESSURE	155 PSI	1069 kPa
BEP HEAD	285'	86.9 m
BEP FLOW	2200 GPM	500 m <sup>3</sup> /h
BEP PERCENT	86%	86%



A typical picture of the pump is shown. Please contact StarTech Pump Company for further details. All information is approximate and for general guidance only.

The 5RB general purpose pump is designed with Gemstone's renowned quality and durability. It features a 5" discharge and a 8" suction, enclosed multi-vane **impeller and flanged tangential double volute**. The pump end mounts to F16, F18, EM16, EM18, VC16, VC18, VF16 and VF18 bearing frames. Optional Redi-Prime or Venturi Prime priming system is available. Bearings are heavy-duty, grease lubricated, single ball bearings with a minimum of 20,000 hours bearing life.

- External hydraulic balance line
- Back pullout design
- Replaceable hub & suction wearings
- Replaceable shaft sleeve
- **High efficiency hydraulics**
- Low operating costs
- Modular bearing frame
- Long B-10 bearing life (20,000 hour min.)
- Two year warranty
- Optional Cycloseal® with type 1 mechanical seal
- Optional Run-Dry™ lubrication system
- Grease lubrication standard - oil lubrication optional
- **SAE #1, 2, 3 & 4 engine mount available to fit**
- Oversized shaft and bearings
- Double volute

PARTS	STANDARD MATERIAL (CAST IRON BRONZE FITTED)
	WEAR RINGS
IMPELLER	Bronze SAE 40
VOLUTE	Cast Iron ASTM A48 CL30
SHAFT	SAE 1144 Stressproof Steel
SHAFT SLEEVE	Bronze SAE 660
BACKPLATE	Cast Iron ASTM A48 CL30
PACKING (STANDARD)	Graphited Acrylic
MECHANICAL SEAL (OPTIONAL)	Single T-1, Buna, Carbon/ Ceramic
BEARING FRAME	Cast Iron ASTM A48 CL30



AGRICULTURE



FOOD



INDUSTRIAL



MINING



MUNICIPAL



OIL & GAS



REFRIGERATION



RENTAL

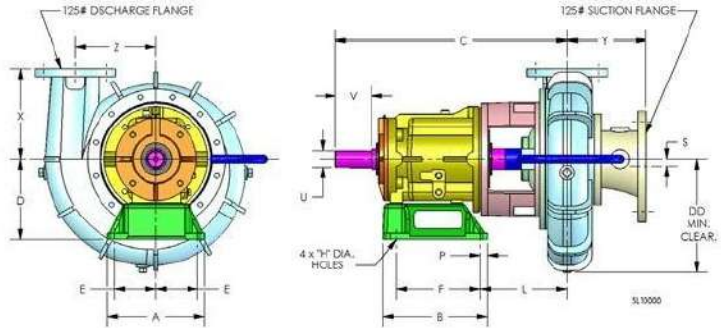
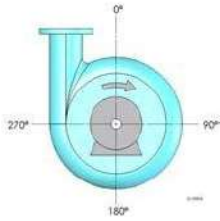

**NOTES:**

Discharge positions are viewed from the drive end.  
Standard increments of discharge position are shown  
in the chart below (DISCH INCR). Consult factory for  
other discharge positions.

**PUMP DIMENSIONS**

MODEL	FRAME	CONNECTION		DISCH. INC.	A	B	C	D	DD	E	F	H	L	P	S	U	V	X	Y	Z	KEYWAY
		DISCH.	SUCT.																		
5RB	F16	5	8	90°	12	12.88	28.62	9.75	14.25	5.12	10.38	0.81	10.77	0.88	0.88	2	4.5	11	9.78	10	.50X.25

Feet x .305 = Meters  
Inches x 25.4 = Millimeters  
GPM x .227 = Cubic Meters/Hour  
GPM x 3.785 = Liters/Minute  
HP x .746 = KW

Speed	Impeller Dia.	Style	Solids Dia.	N <sub>S</sub>	Suction	Discharge	No. vanes
VARIOUS	VARIOUS	ENCLOSED	1"	1654	8"	5"	6

**DOUBLE VOLUTE MOUNTING CONFIG.: CC, VM, F, VF, EM, VC**

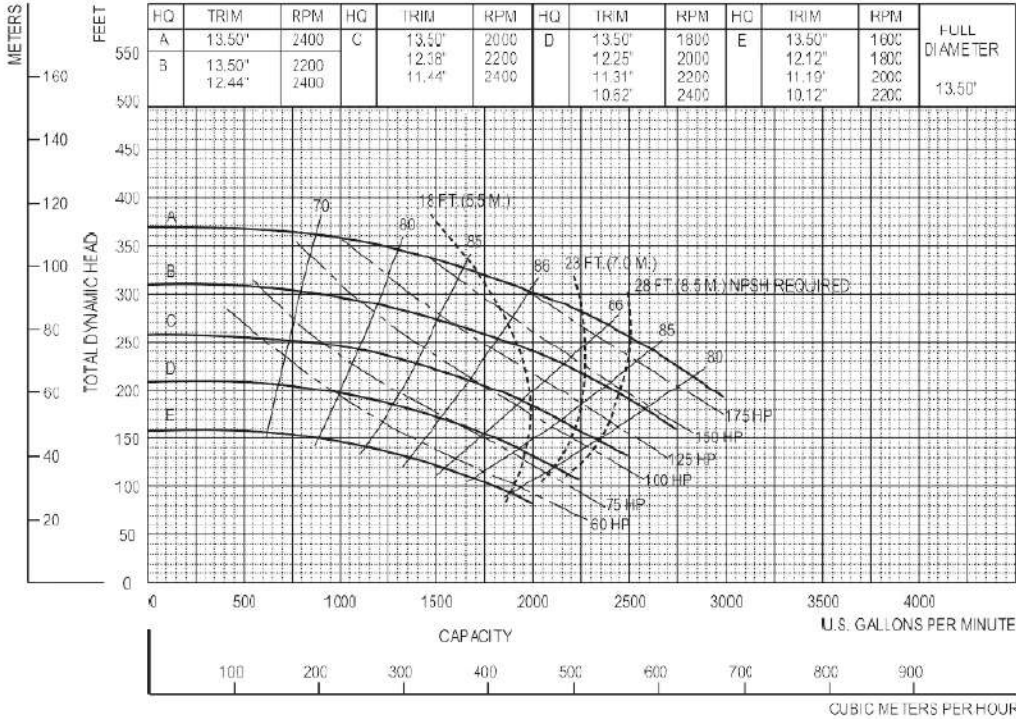

Performances shown are for cold water, close-coupled electric configuration with Cycloset®. Other mounting configurations, see arrangements in manual for impeller and/or performance adjustments.

NEW PAGE

5RBVA

StarTech Pump Company	5RB - VARIOUS RPM
-----------------------	-------------------

12/1/02