

AVAILABLE MOUNTING CONFIGURATIONS

5HH-RP-F REDI-PRIME FRAME MOUNT
5HH-F FRAME MOUNT
5HH-RP-EM REDI-PRIME ENGINE MOUNT
5HH-EM ENGINE MOUNT
5HH-VF VERTICAL FRAME MOUNT
5HH-VC VERTICAL COUPLED

OPERATING LEVELS

MIN FLOW	650 GPM	147.6 m ³ /h
MAX FLOW	2950 GPM	669.7 m ³ /h
DISCHARGE SIZE	5"	127 mm
SUCTION SIZE	8"	203 mm
SOLIDS HANDLING	.75"	1.9 cm
MAX SPEED	2000 RPM	2000 RPM
SHUT-OFF HEAD	375'	114.3 m
BEP HEAD	330'	100.6 m
BEP FLOW	2200 GPM	499.4 m ³ /h
BEP PERCENT	85%	85%



Atypical picture of the pumps shown. Please contact StarTech Pump Company for further details. All information is approximate and for general guidance only.

PARTS	CAST IRON BRONZE FITTED (STANDARD)	ALL IRON
IMPELLER	BRONZE SAE 40	CAST IRON ASTM A48 CL30
VOLUTE	CAST IRON ASTM A48 CL30	CAST IRON ASTM A48 CL30
SHAFT	SAE 1144 "STRESSPROOF"	SAE 1144 "STRESSPROOF"
SHAFT SLEEVE	BRONZE SAE 660	416 STAINLESS STEEL
BEARING HOUSING	CAST IRON ASTM A48 CL30	CAST IRON ASTM A48 CL30
WEAR RINGS	BRONZE SAE 660	CAST IRON ASTM A48 CL30
SUCTION SPOOL	CAST IRON ASTM A48 CL30	CAST IRON ASTM A48 CL30
BACKPLATE	CAST IRON ASTM A48 CL30	CAST IRON ASTM A48 CL30
MECHANICAL SEAL (OPTIONAL)	T-1, BUNA, CARBON/CERAMIC/STAINLESS	T-1, BUNA, CARBON/CERAMIC/STAINLESS
PACKING	GRAPHITED ACRYLIC	GRAPHITED ACRYLIC

The 5H pump is designed with StarTech's renowned quality and durability. It features a 5" discharge, 8" suction, **enclosed impeller, and flanged tangential double volute. Available in all-iron or bronze-fitted materials. Graphited acrylic packing is standard, with StarTech's patented Cycloseal[®] available (with type 1 single mechanical seal).** Grease lubrication standard - oil lubrication optional.

- External hydraulic balance line
- Back pullout design
- Replaceable hub & suction wear rings
- **Replaceable shaft sleeve**
- **High efficiency hydraulics**
- Low operating costs
- SAE #1, 2, 3, 4 & 5 •
Modular bearing frame •
Oversized shaft and bearings •
Other mechanical seal (Cycloseal[®]) and material options available
- Two year warranty



AGRICULTURE



FOOD



INDUSTRIAL



MINING



MUNICIPAL



OIL & GAS



REFRIGERATION



RENTAL

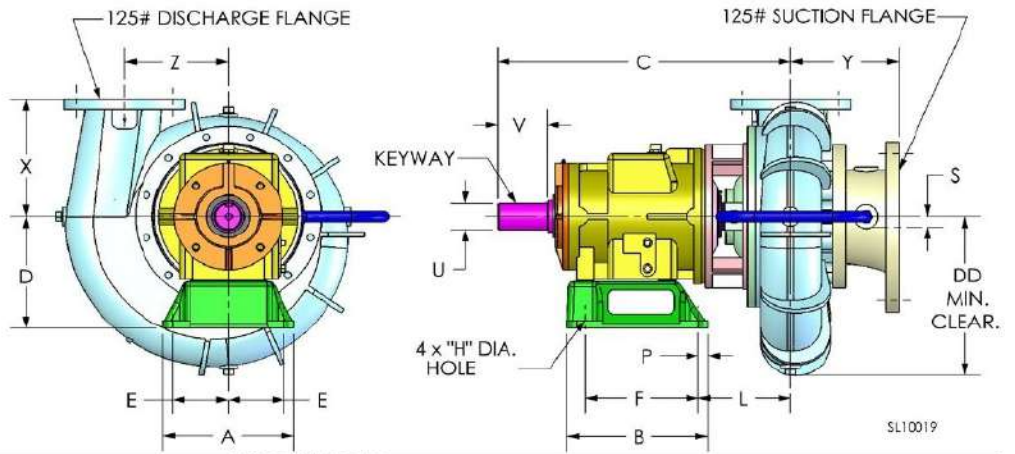

PUMP DIMENSIONS

MODEL	FRAME	CONNECTION		DISCH. INCR.	A	B	C	D	DD	E	F	H	L	P	S	U	V	X	Y	Z	KEYWAY
		DISCH.	SUCT.																		
3HA	F18	3	6	90°	12	12.88	29.11	10.5	11.12	5.12	10.38	0.81	10.74	0.88	0.44	2.5	4.5	10	8.53	8.5	.62X.31
3HC	F18	3	6	90°	12	12.88	25.88	10.5	11.12	5.12	10.38	0.81	7.5	0.88	0.44	2.5	4.5	10	8.53	8.5	.62X.31
4HC	F18	4	8	90°	12	12.88	26.97	10.5	12.62	5.12	10.38	0.81	8.6	0.88	0.88	2.5	4.5	11	10.88	9.75	.62X.31
4HH	F18	4	6	90°	12	12.88	29.14	10.5	15	5.12	10.38	0.81	10.77	0.88	0.44	2.5	4.5	9.5	8.97	11.25	.62X.31
5H	F18	5	8	90°	12	12.88	29.17	10.5	14.75	5.12	10.38	0.81	10.8	0.88	0.88	2.5	4.5	13	9.66	11.62	.62X.31
5HH	F18	5	8	90°	12	12.88	29.84	10.5	16.25	5.12	10.38	0.81	11.47	0.88	0.44	2.5	4.5	11	10.56	10.25	.62X.31
6H	F18	6	8	90°	12	12.88	29.14	10.5	14.75	5.12	10.38	0.81	10.77	0.88	0.44	2.5	4.5	14	10.18	11.62	.62X.31
6HH	F18	6	8	90°	12	12.88	30.13	10.5	17.12	5.12	10.38	0.81	11.91	0.88	0.44	2.5	4.5	12	10.43	12	.62X.31
8H	F18	8	10	90°	12	12.88	30.41	10.5	16.75	5.12	10.38	0.81	12.03	0.88	0.75	2.5	4.5	13	10.41	11.5	.62X.31

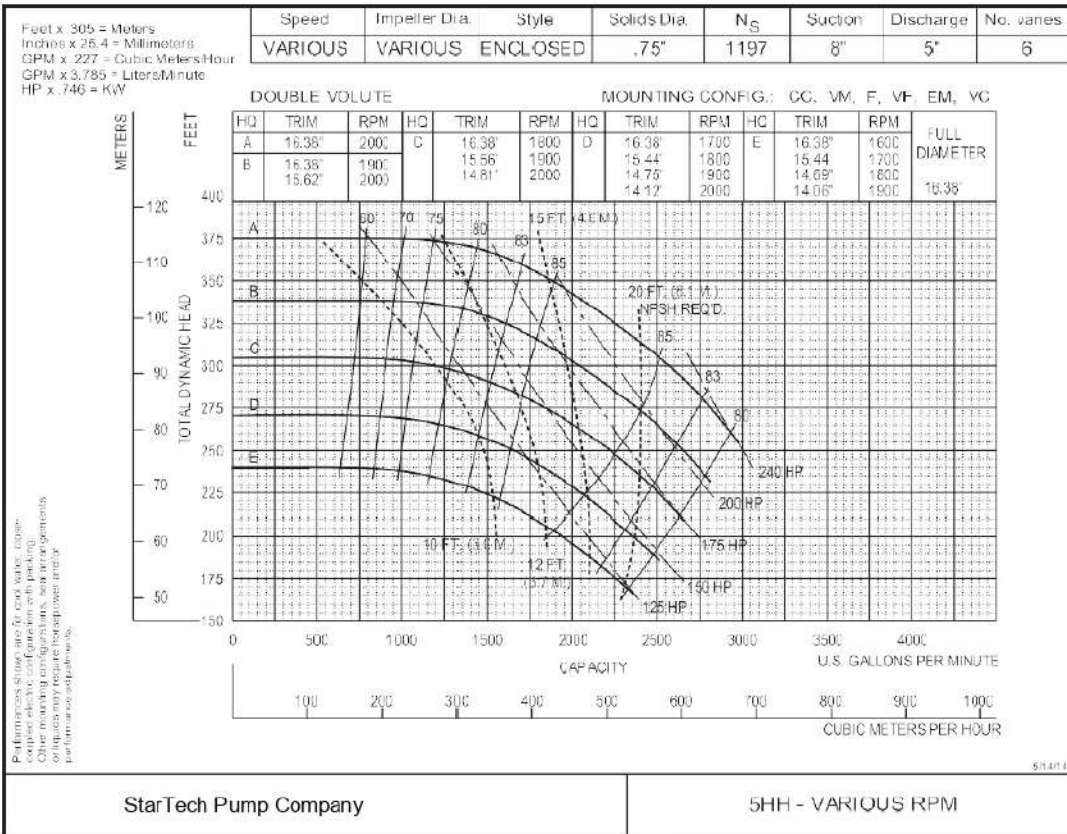

NEW PAGE
5HHVA