

**STARTECH PUMP COMPANY**

500 - 1200 GPM

Model 4HM

150 - 375 Feet TDH

STANDARD SPECIFICATION**Discharge** - 3 inch discharge**Suction** - 5 inch suction**Impeller** - Semi-open, threaded, 3 vane: handles
1" solids**Volute** - Right and left hand tangential discharge, eight
positions**Mechanical Seal or Traditional Packing** - Single,
type 2, silicon carbide/tungsten carbide mechanical
seal: Cycloseal® design, Run-dry available**Materials of Construction**

- Cast iron casing, cast iron impeller
- Other materials available

MOUNTING OPTIONS

- **Close Coupled Electric**
 - StarTech's Energy Efficient Design
- **Frame Mount**
 - StarTech's F16
 - StarTech's F18
 - StarTech's F18DB
- **Engine Bracket**
 - StarTech's EM16 (SAE 1, 2, 3, 4)
 - StarTech's EM18 (SAE 1, 2, 3, 4)
 - StarTech's EM18DB (SAE 1, 2, 3, 4)
- **Oil Filled Bearing Frame**
 - Available

AVAILABILITY

- **Quick Ship**
 - Finished Product Regularly Stocked
(48 Hours)
- **Preferred Pump**
 - Finished Components Regularly Stocked
(10 business days)
- **Specialty Pump**
 - StarTech Pump Company will design
and manufacture a variation of this pump
specifically designed for your application

**FEATURES & BENEFITS**

- **Cornell's Tradition of Excellence:**
 - **Highest quality products**
 - **Experience**
 - Over 50 years in the centrifugal pump business
 - **Optimum Hydraulics**
 - In house engineering staff and test lab facilities
 - **Strong Local Dealer Support**
 - Our agricultural products are sold only through
authorized dealerships
 - Dealerships provide full service to customers from
sales to replacement parts
 - Dealers maintain and improve their knowledge at
educational activities like StarTech's "Pump
School"
- **Exceptional Design:**
 - **Efficiency**
 - Effectively converts energy into fluid flow and
pressure
 - **Long Product Life**
 - Thick walled castings -
 - Heavy duty shafts -
 - 20,000 hour bearings -
 - Replaceable wear rings and shaft sleeves -
 - Reduced thrust load through design and balance
lines where appropriate

PERFORMANCE CURVES

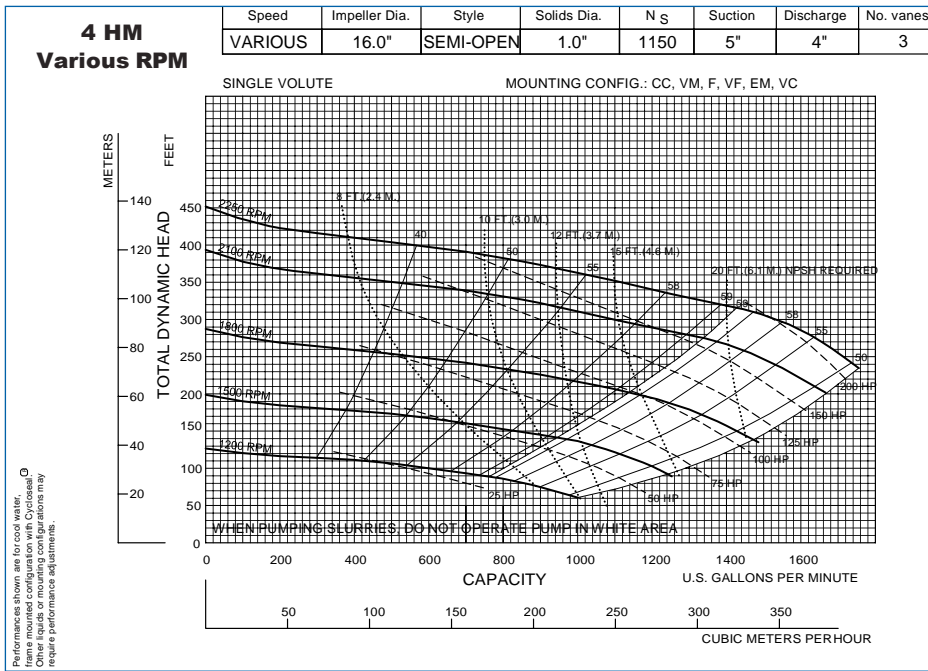

Note:
 Curves also available in 1800 and 1200 RPM

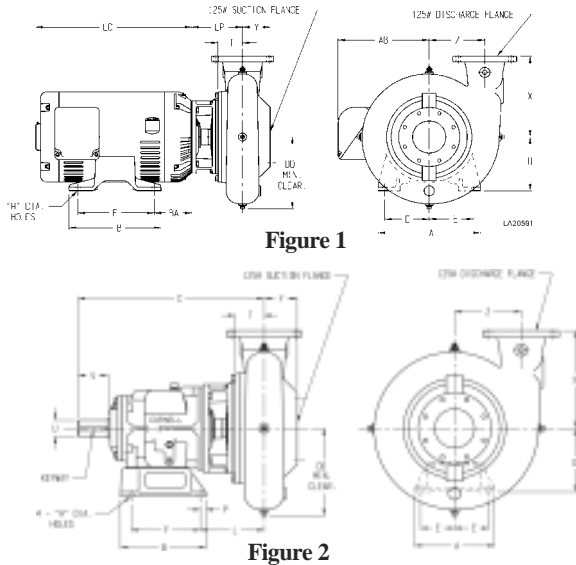

Figure 1

Figure 2

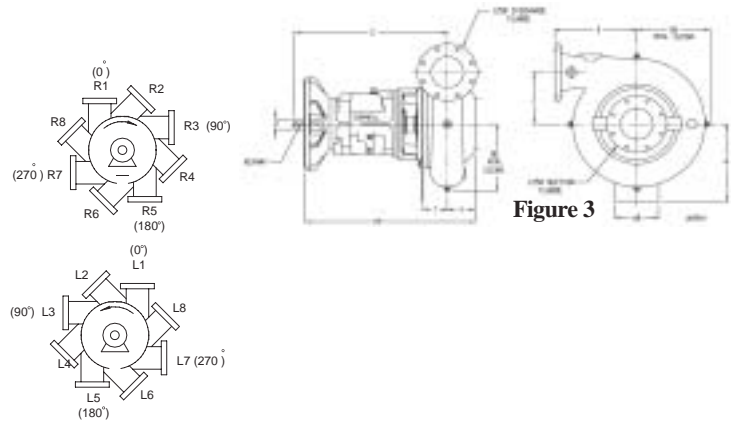

Figure 3

PUMP DIMENSIONS

MOUNT	Fig.	A	AR	B	C	CP	D	DA	DD	E	F	H	L	LP	P	R	T	U	V	X	Y	Z	KEYWAY
CC	1	-	-	-	-	-	-	-	12.62	-	-	-	-	11.19	-	-	3.03	-	-	11	3.09	9.75	-
F16	2	12	-	12.88	25.95	-	9.75	-	12.62	5.12	10.38	0.81	8.09	-	0.88	-	3.03	2	4.5	11	3.09	9.75	.50 X .25
F18	2	12	-	12.88	25.94	-	10.5	-	12.62	5.12	10.38	0.81	8.09	-	0.88	-	3.03	2.5	4.5	11	3.09	9.75	.62 X .31
EM16	3	-	5.25	-	25.95	27.03	-	12.62	12	-	-	-	-	-	-	16.77	3.03	2	-	11	3.09	9.75	.50 X .25
EM18	3	-	5.25	-	25.94	27.03	-	12.62	12	-	-	-	-	-	-	16.77	3.03	2.5	-	11	3.09	9.75	.62 X .31

StarTech Pump Company

MOTOR DIMENSIONS

MOTOR FRAME	AK DIM.	A	B	D	E	F	H	AB	BA	LC
213-5	8.5	9.5	8	5.25	4.25	7	0.41	7.94	4.5	13.69
254-6	8.5	11.25	11.25	6.25	5	10	0.53	9.5	5	17.94
284-6	12.5	12.25	12.25	7	5.5	11	0.53	11.37	5	21.31
324-6	12.5	14.25	13.75	8	6.25	12	0.66	12.22	5.5	22.19
364-5	12.5	15.75	14	9	7	12.25	0.66	13.2	6.12	24.31
404-5	12.5	18.49	16.62	10	8	13.75	0.81	16.39	6.88	28.22

ISO9001:2000 CERTIFIED