



STARTECH PUMP COMPANY

3WM Trash Pump

STANDARD SPECIFICATIONS

- **Discharge** - 3 inch discharge
- **Suction** - 4 inch suction
- **Impeller** - Class 30 Cast Iron, Semi Open with 1.2 inch solid handling capability
- **Volute** - Class 30 Cast Iron with right hand tangential discharge
- **Shaft Sleeve** - Stress proof stainless steel
- **Seal** - Patented Cycloseal® with integral Run Dry system

FEATURES & BENEFITS

- Fully automatic self prime pump with Bendix compressor available for unattended reprime
- Patented Cycloseal® with integral Run Dry system
- Heavy duty “wet end” construction
- Manufactured in the United States

PERFORMANCE CHARACTERISTICS

- Premium Hydraulic Efficiencies, BEP at 66%
- Exceptional NPSHR Characteristics, 15 feet at BEP
- Suction lift capability up to 28 feet
- Total Dynamic Head: 60 to 220 feet
- Capacity: 100 to 600 GPM

FEATURES & BENEFITS

- **Close Coupled** - 4 pole (1800 RPM, 60Hz)
- **Frame Mount** - F5, F5K Bearing Frame
- **Engine Mount** - EM5 Bearing Frame (SAE 3, 4)

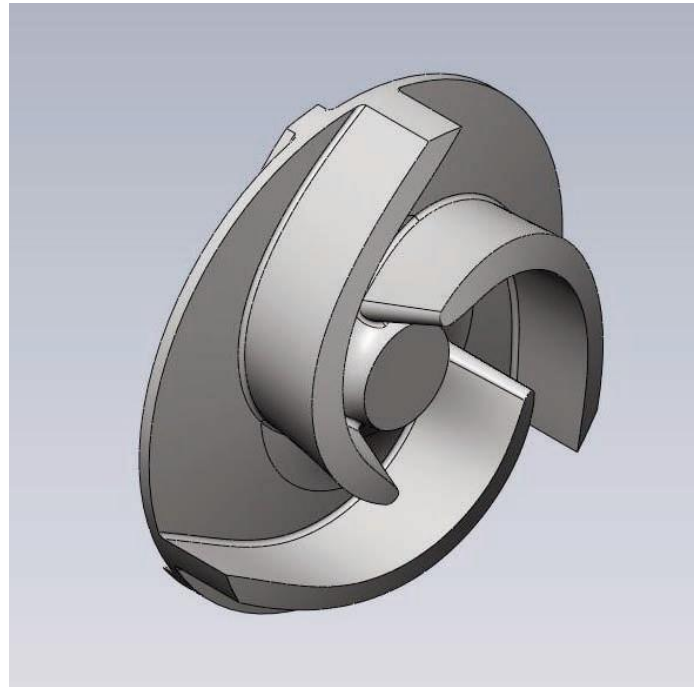
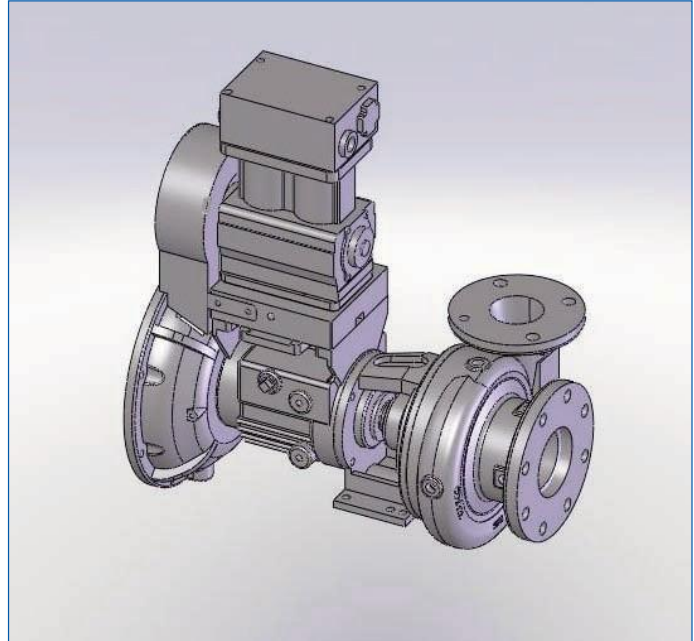

PERFORMANCE CURVES

Feet x .305 = Meters
 Inches x 25.4 = Millimeters
 GPM x .227 = Cubic Meters/Hour
 GPM x 3.785 = Liters/Minute
 HP x .746 = KW

Speed	Impeller Dia.	Style	Solids Dia.	N _S	Suction	Discharge
VARIOUS	7.18"	SEMI-OPEN	1.20"	2240	4"	3"

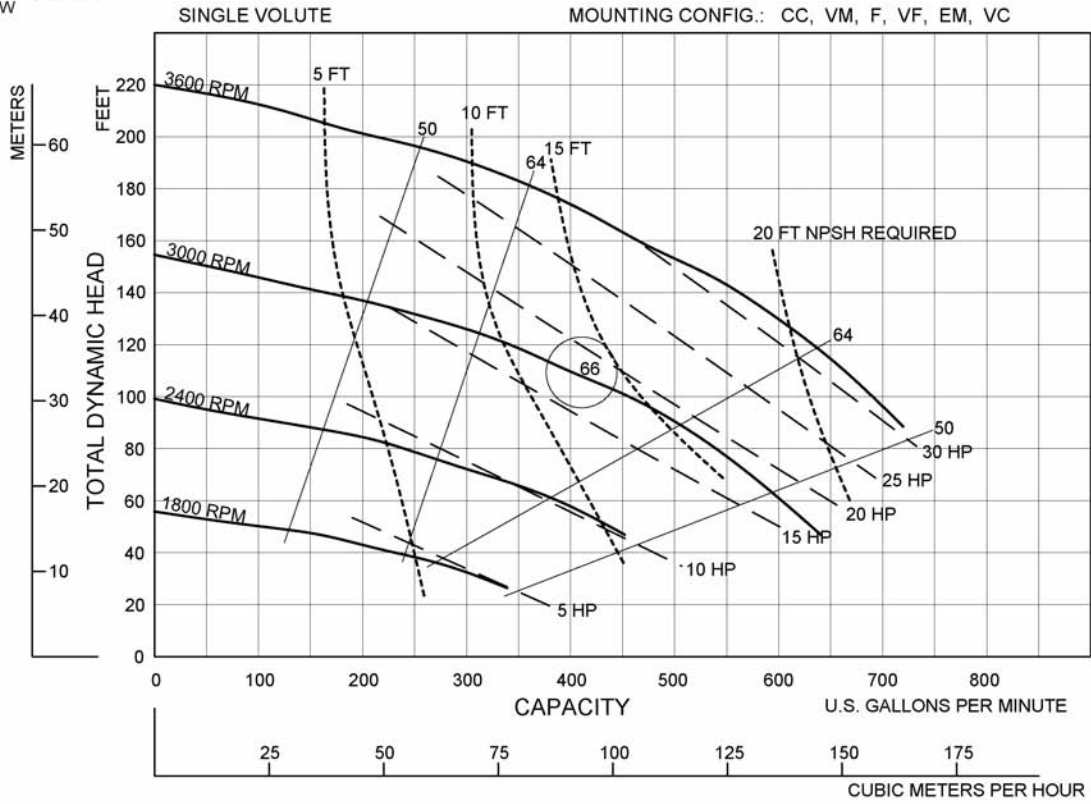

Performances shown are for cool water, close to normal conditions. Other mounting styles or liquids may require horsepower and/or performance adjustments.

4/16/10

StarTech Pump Company

CERTIFIED TO ISO 9001:2000