

AVAILABLE MOUNTING CONFIGURATIONS

3HC-F FRAME MOUNT
3HC-RP-F REDI-PRIME FRAME MOUNT
3HC-EM ENGINE MOUNT
3HC-RP-EM REDI-PRIME ENGINE MOUNT
3HC-VC VERTICAL COUPLED
3HC-VF VERTICAL FRAME MOUNT

OPERATING LEVELS

MIN FLOW	100 GPM	23 m ³ /h
MAX FLOW	1070 GPM	243 m ³ /h
DISCHARGE SIZE	3"	76 mm
SUCTION SIZE	6"	152 mm
SOLIDS HANDLING	.5"	12.7 mm
MAX SPEED	2400 RPM	2400 RPM
SHUT-OFF HEAD	480'	146 m
BEP HEAD	440'	134 m
BEP FLOW	929 GPM	211 m ³ /h
BEP PERCENT	72%	72%

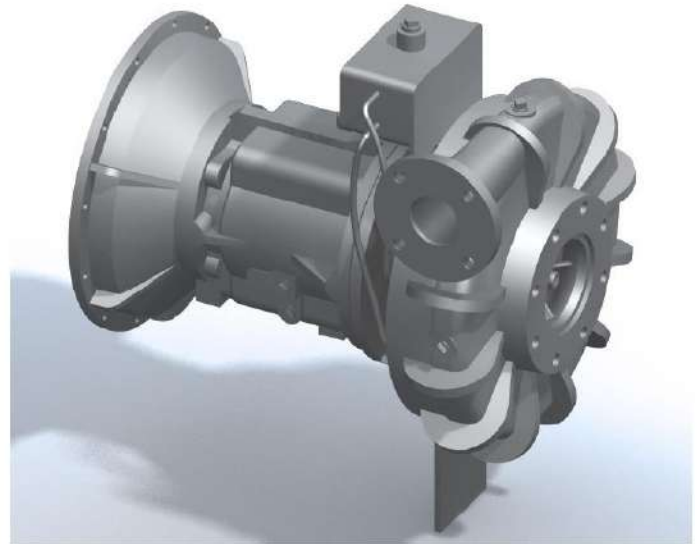

A typical picture of the pump is shown. Please contact StarTech Pump Company for further details. All information is approximate and for general guidance only.

PARTS	STANDARD MATERIAL (ALL IRON)
WEAR RING	CAST IRON
IMPELLER	CA6NM STAINLESS STEEL
VOLUTE	CAST IRON
SHAFT	STRESSPROOF STEEL
SHAFT SLEEVE	416 STAINLESS STEEL
MECHANICAL SEAL	T-1 OR T-2, BUNA, CARBON/CERAMIC/STAINLESS
BEARING FRAME	CAST IRON

The 3HC pump is designed with StarTech's renowned quality and durability. It features a 3" discharge, 6" suction, and enclosed impeller. StarTech's patented Cycloseal® design is standard, with a Type 1 or 2 single mechanical seal with Buna-N elastomers, stainless steel hardware and carbon vs. ceramic seal faces for abrasion resistance.

- Patented Cycloseal® design
- Heavy duty construction
- Two-year warranty
- Oversized shaft and bearings
- Redi-Prime® available for fully-automatic continuous priming
- **RunDry™ option (Indefinite run dry capability)**



AGRICULTURE



FOOD



INDUSTRIAL



MINING



MUNICIPAL



OIL & GAS



REFRIGERATION



RENTAL

