

### AVAILABLE MOUNTING CONFIGURATIONS

**2VH-CC CLOSE-COUPLED**

### OPERATING LEVELS

MIN FLOW	<b>56 GPM</b>	<b>12.9 m<sup>3</sup>/h</b>
MAX FLOW	<b>475 GPM</b>	<b>109.3 m<sup>3</sup>/h</b>
DISCHARGE SIZE	<b>2"</b>	<b>51 mm</b>
SUCTION SIZE	<b>2.5"</b>	<b>64 mm</b>
MAX IMPELLER DIA.	<b>8"</b>	<b>20.3 cm</b>
SOLIDS HANDLING	<b>.25"</b>	<b>6.4 mm</b>
MAX SPEED	<b>3600 RPM</b>	<b>3600 RPM</b>
MAX PRESSURE	<b>175 PSI</b>	<b>1207 kPa</b>
SHUT-OFF HEAD	<b>235'</b>	<b>71.6 m</b>
BEP HEAD	<b>215'</b>	<b>65.5 m</b>
BEP FLOW	<b>280 GPM</b>	<b>64.4 m<sup>3</sup>/h</b>
BEP	<b>72%</b>	<b>72%</b>



A typical picture of the pump is shown. Please contact StarTech Pump Company for further details. All information is approximate and for general guidance only.

The 2VH pump is designed with StarTech's renowned quality and durability. It features a 2" discharge, 2.5" suction, tangential volute and enclosed impeller. A type 21 single mechanical seal is standard, with Buna-N elastomers, stainless steel hardware and silicon carbide vs. silicon carbide seal faces. The 2VH comes standard with an open drip-proof motor that operates between 1800 and 3600 RPM; other motor options are available including TEFC and others.

- Standard iron construction with stainless shaft sleeve
- Back pull-out design
- Replaceable suction wear ring and shaft sleeve
- High efficiency hydraulics
- Low operating costs
- Two-year warranty
- Other mechanical seal options available
- FIPT connections

PARTS	STANDARD MATERIAL
WEAR RING	<b>DUCTILE IRON</b>
IMPELLER	<b>CAST IRON</b>
VOLUTE CASING	<b>CAST IRON</b>
SHAFT	<b>CARBON STEEL</b>
SHAFT SLEEVE	<b>303 STAINLESS STEEL</b>
BACKPLATE / BRACKET	<b>CAST IRON</b>
MECHANICAL SEAL	<b>T-21, BUNA, SILICON CARBIDE FACES</b>
MOTOR	<b>ODP W/ 1.15 SF</b>



AGRICULTURE



FOOD



INDUSTRIAL



MINING



MUNICIPAL



OIL & GAS



REFRIGERATION



RENTAL

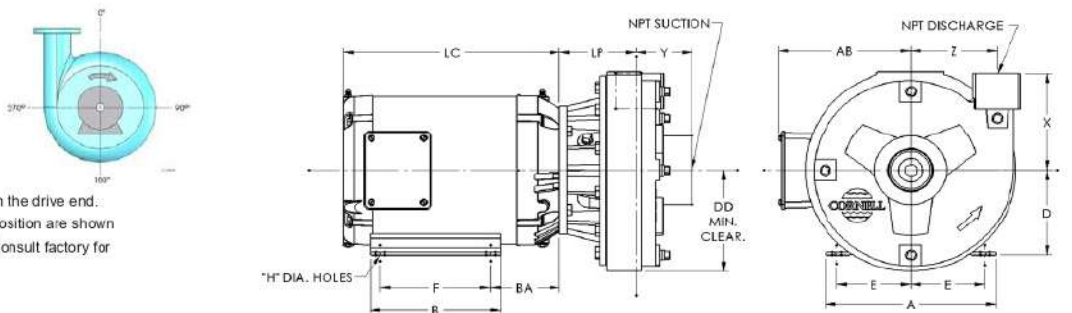
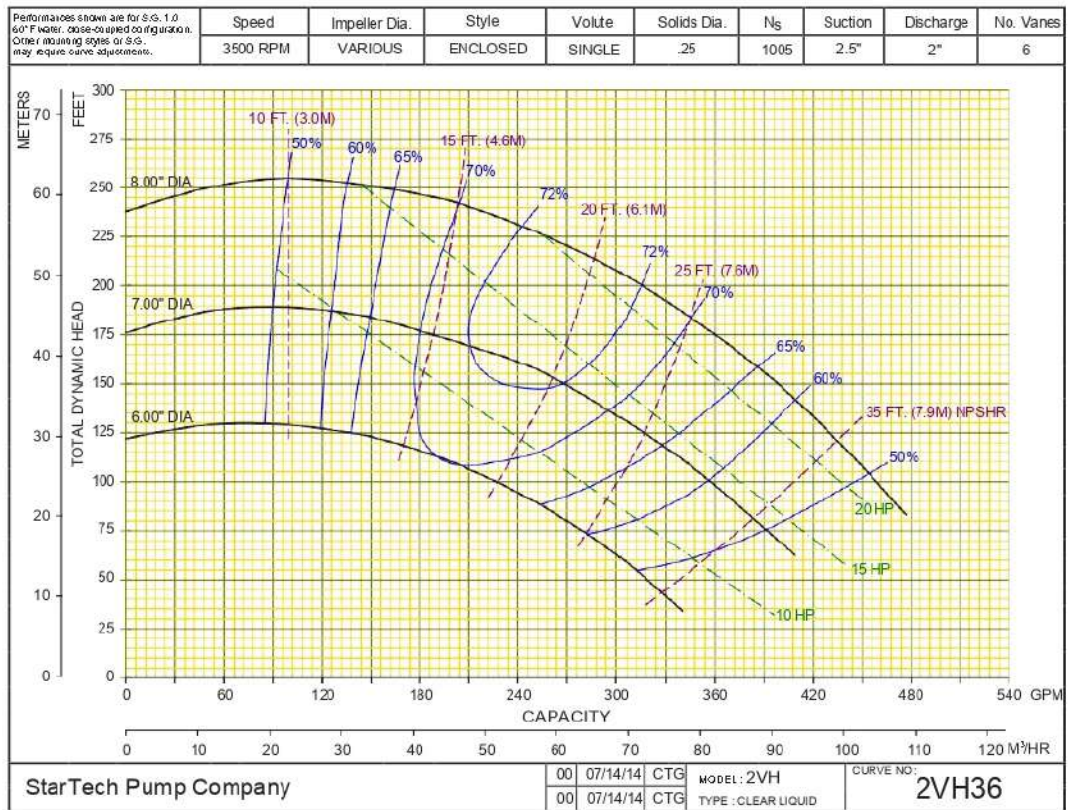

**NOTES:**

Discharge positions are viewed from the drive end.  
Standard increments of discharge position are shown  
in the chart below (DISCH INCR). Consult factory for  
other discharge positions.

PUMP DIMENSIONS*									
MODEL	CONNECTION		DISCH. INCR.	AK DIM.	DD	X	Y	Z	LP
	DISCH.	SUCT.							
2VH	2 NPT	2½ NPT	90°	4.5	5½	6	3⅝	4⅞	4⅞
	2 NPT	2½ NPT	90°	8.5	5½	6	3⅝	4⅞	4¼
	2 NPT	2½ NPT	90°	8.5	5½	6	3⅝	4⅞	see factory
	2 NPT	2½ NPT	90°	12.5	5½	6	3⅝	4⅞	see factory

\*Consult Factory for Motor Dimensions