

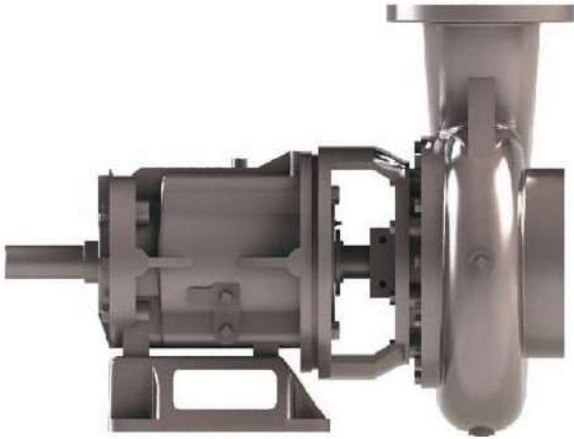

STARTECH PUMPS COMPANY

Model 10NNT-F



- Size: 10NNT - 10" discharge x 10" suction with 125# cast iron flanges.
- Casing: Cast Iron.
- Impeller: Enclosed - 2 vane. Handles 3.38" diameter solids.
- Wear Rings: Replaceable. (Double wear rings available).
- Seal: StarTech's patented Cycloseal® design system. John Crane T-2 single mechanical seal with Viton® elastomers, stainless steel hardware and tungsten- vs. siliconcarbide seal faces for abrasion resistance.
- Shaft Sleeve: 416 stainless steel.
- Bearings: Heavy duty, grease lubricated, deep groove ball bearings, with a minimum of 50,000 hours bearing life.

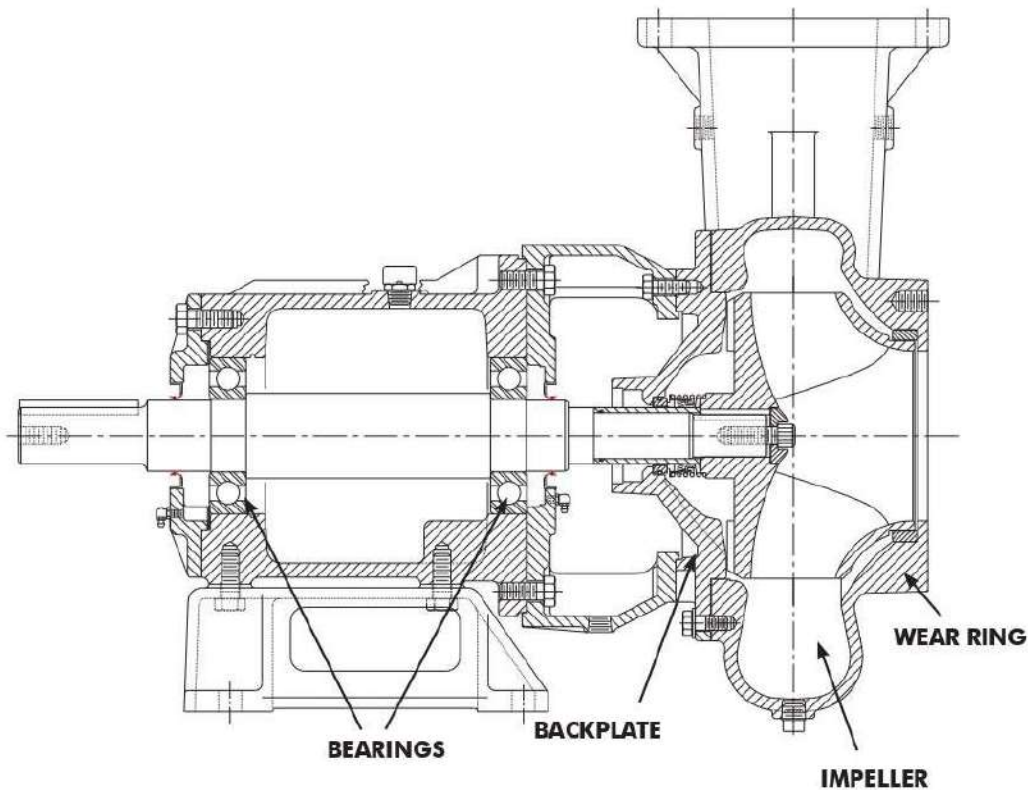

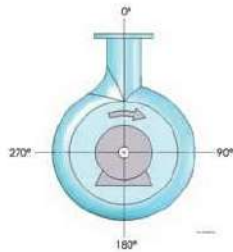

NOTES:

Discharge positions are viewed from the drive end.
 Standard increments of discharge position are shown in the chart below (DISCH INCR). Consult factory for other discharge positions.

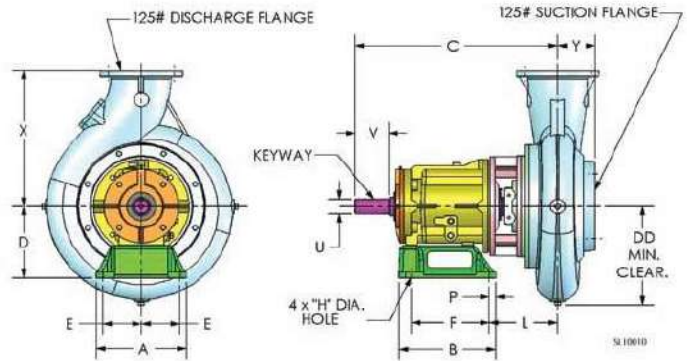

NOTES:

1. "V" Dimension is maximum useable shaft.
2. Frame mounting foot thickness is .75".
3. Flange connection dimension can vary $\pm .12$ inch.
4. Do not use for construction unless certified.

