

**STARTECH PUMP COMPANY**

100 - 400 GPM

Model 2.5YM 50 - 350 Feet TDH**STANDARD SPECIFICATION****Discharge** - 2.5 inch discharge**Suction** - 4 inch suction**Impeller** - Semi-open, 4 vane: handles .88" solids**Volute** - Centerline discharge, eight positions**Mechanical Seal or Traditional Packing** - Single, type 21, silicon carbide/tungsten carbide mechanical seal: Cycloseal® design, Run-dry available**Materials of Construction**

- Cast iron casing, cast iron impeller
- Other materials available

MOUNTING OPTIONS**• Close Coupled Electric**

StarTech Energy Efficient Design

• Frame Mount

StarTech F16

• Engine Bracket

StarTech EM16 (SAE 1, 2, 3, 4)

AVAILABILITY**• Quick Ship**

- Finished Product Regularly Stocked (48 Hours)

• Preferred Pump

- Finished Components Regularly Stocked (10 business days)

• Specialty Pump

StarTech Pump Company will design and manufacture a variation of this pump specifically designed for your application

**FEATURES & BENEFITS****• StarTech's Tradition of Excellence:**

- **Highest quality products**
- **Experience**
 - Over 50 years in the centrifugal pump business

- **Optimum Hydraulics**

- In house engineering staff and test lab facilities

- **Strong Local Dealer Support**

- Our agricultural products are sold only through authorized dealerships
 - Dealerships provide full service to customers from sales to replacement parts
 - Dealers maintain and improve their knowledge at educational activities like StarTech's "Pump School"

• Exceptional Design:

- **Efficiency**
 - Effectively converts energy into fluid flow and pressure
- **Long Product Life**
 - Thick walled castings - Heavy duty shafts
 - 20,000 hour bearings - Replaceable wear rings and shaft sleeves - Reduced thrust load through design and balance lines where appropriate

PERFORMANCE CURVES

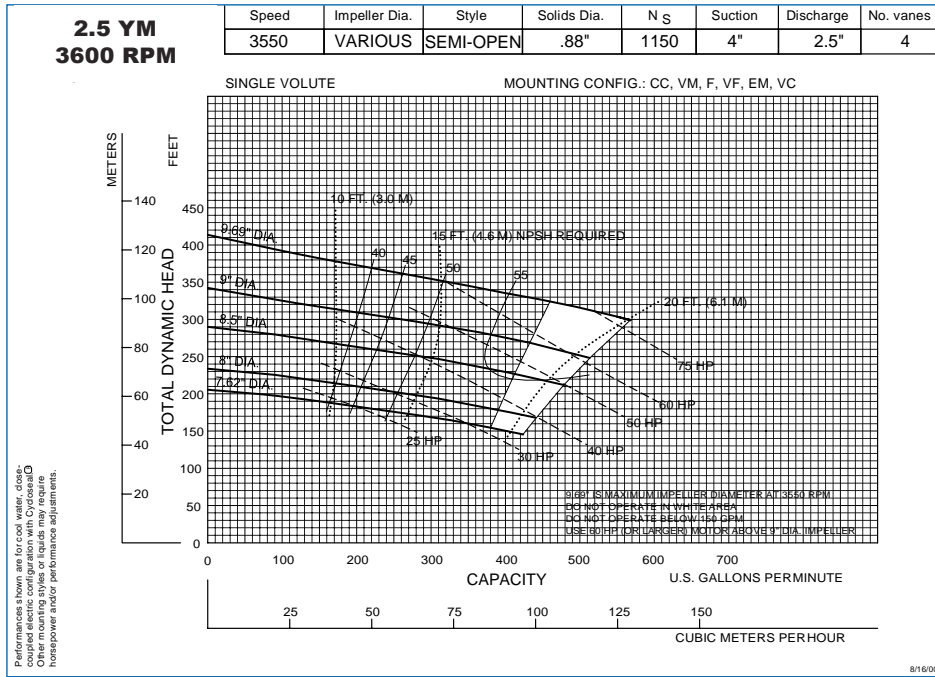

Note:
Curves also available in 1800 and various RPM

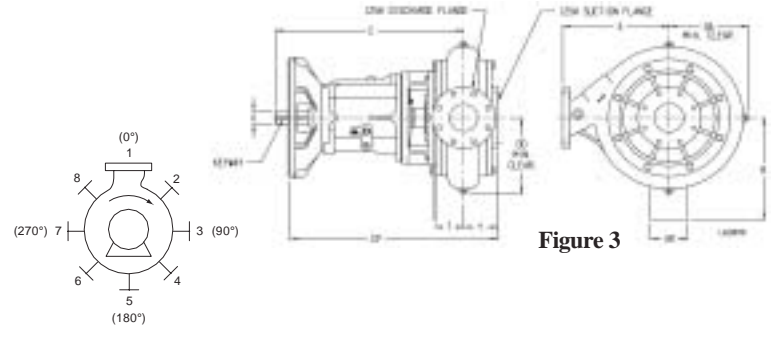
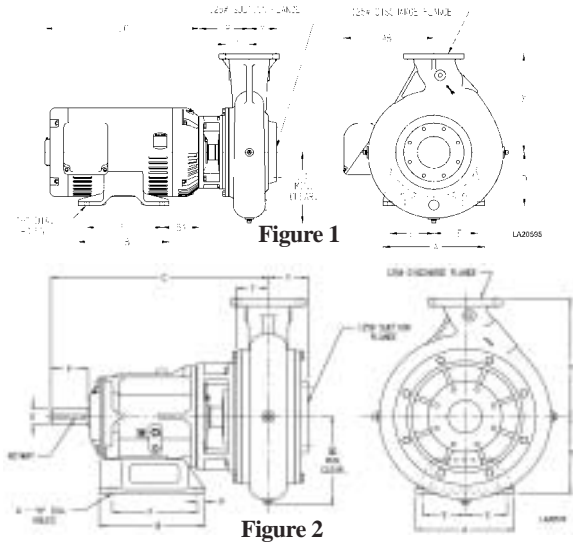

PUMP DIMENSIONS

MOUNT	Fig.	A	AR	B	C	CP	D	DA	DD	E	F	H	L	LP	P	R	T	U	V	X	Y	Z	KEYWAY
CC	1	-	-	-	-	-	-	-	8	-	-	-	-	7.70	-	-	2.75	-	-	9.31	2.95	-	-
CC	1	-	-	-	-	-	-	-	8	-	-	-	-	7.70	-	-	2.75	-	-	9.31	2.95	-	-
F16	2	12	-	12.88	25.7	-	9.75	-	8	5.12	10.38	0.81	7.84	-	0.88	-	2.75	2	4.5	9.31	2.95	-	.50 X .25
EM16*	3	-	5.25	-	-	26.64	-	-	7.5	-	-	-	-	-	-	11.46	2.75	2	-	9.31	2.95	5.38	.50 X .25

*Support plate mounted on suction flange

StarTech Pump Company

MOTOR DIMENSIONS

MOTOR FRAME	AK DIM.	A	B	D	E	F	H	AB	BA	LC
213-5	8.5	9.5	8	5.25	4.25	7	0.41	7.94	4.5	13.69
254-6	8.5	11.25	11.25	6.25	5	10	0.53	9.5	5	17.94
284-6	12.5	12.25	12.25	7	5.5	11	0.53	11.37	5	21.31
324-6	12.5	14.25	13.75	8	6.25	12	0.66	12.22	5.5	22.19
364-5	12.5	15.75	14	9	7	12.25	0.66	13.2	6.12	24.31
404-5	12.5	18.49	16.62	10	8	13.75	0.81	16.39	6.88	28.22

ISO9001:2000 CERTIFIED